

# KUNZMANN® FRÄSMASCHINEN

WF 410 MC+  
WF 610 MC+

UNIVERSAL MILLING AND DRILLING MACHINE



**The plus+ in KUNZMANN's WF 410 MC+ and WF 610 MC+ stands for extra dynamics and optimized positioning – now with linear guideways in all axes.**

With the **WF 410 MC+** and **WF 610 MC+**, we unite our well-known features of high stability and ruggedness due to wide guiding distances with outstanding continuous accuracy.

The generation **MC+** is hence perfect for any milling and drilling operation in modern training and universal processing.

**HYBRID OPERATION CONCEPT**

The unique KUNZMANN combination of CNC and conventional manual operating elements makes the **MC+** an all-rounder: A must-have for training purposes as well as precise single part and small batch production.

Via key switch, you can conveniently switch between Manual Mode and CNC Mode.

In the manual mode, you may operate the **WF 410 MC+** and **WF 610 MC+** like a conventional machine with a 3-axis active digital readout. In addition, you can use the KUNZMANN Positioning Function for single-axis positioning blocks.

With our innovative KUNZMANN manual control panel (with dual-channel buttons), all these functions are also available with open doors and without constant activation of the enabling button. The machine can be operated over the ergonomically installed handwheels, the control, or the electronic handwheel.

In the CNC mode, you have the full functionality of a state-of-the-art contouring control at your disposal.



↑ WF 610 MC+

## SIEMENS SINUMERIK ONE

High-end control with 19" screen and comfortable KUNZMANN manual control panel

Machine operation reaches a new comfort level thanks to the haptic powerride potentiometer with visual display. Highly ergonomic working is guaranteed by the angled and rotatable control panel. The electronic handwheel supports the operator in flexibly setting up and retooling the machine.



### MILLING HEAD

- ▶ This robust all-rounder is a powerful basis for numerous types of operations. Flexibility is guaranteed by the extendible quill and the option to swivel the milling head.
- ▶ Spindle speed: up to 5,000 rpm
- ▶ Swivel range: from  $-5^{\circ}$  to  $+90^{\circ}$
- ▶ Torque: up to 85 Nm
- ▶ Performance: up to 10.5 kW



### MOTOR SPINDLE

- ▶ Dynamics and precision at any spindle speed and with minimum noise generation make the motor spindle the state-of-the-art solution for innovative operating procedures.
- ▶ Ceramic bearings for maximum running smoothness and precision
- ▶ Spindle speed: up to 12,000 rpm
- ▶ Torque: up to 64 Nm
- ▶ Performance: up to 14 kW

## LINEAR ENCODERS

Linear encoders ensure optimum precision and long-term accuracy.

## COLLISION PROTECTION COUPLINGS

Extra safety: Mechanic couplings round off our elaborate collision protection concept.

## UNIVERSAL TILTING-SWIVELING TABLE

The universal tilting and swiveling table allows you to position the workpiece in different angular positions.

## CNC DIVIDING HEAD

With a CNC dividing head you may easily process workpieces multilaterally. Programming is done via the 4th axis of the control. You may vertically or horizontally mount the dividing unit on the angular table.

## TOUCH PROBE SYSTEMS AND AUTOMATIC TOOL MEASUREMENT

Combined with the probing cycles of the control, triggering 3D touch probe systems facilitate setup, measuring, and monitoring during manufacturing. Specific control cycles are used to automatically measure tool length, tool radius, and tool wear with a matching probe.



CNC dividing head (1),  
touch probe system and automatic  
tool measurement (2)



**WF 410 MC+ / WF 610 MC+**

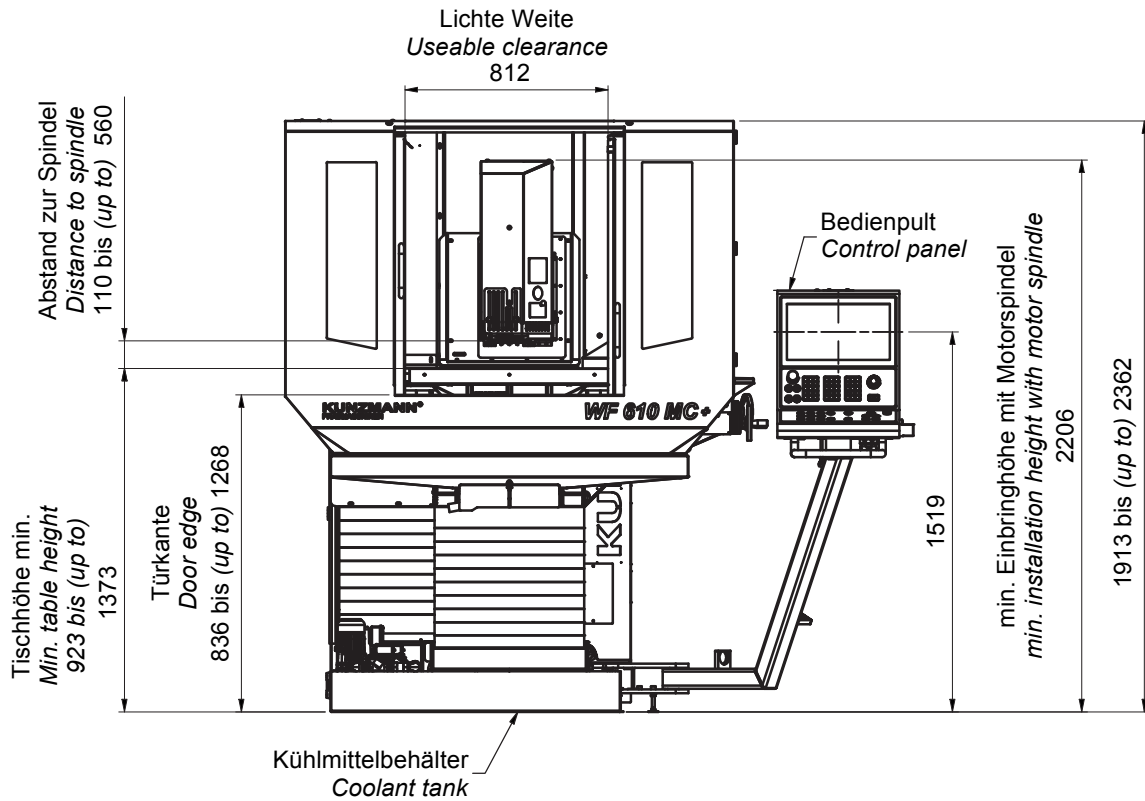

**WF 410 MC+**

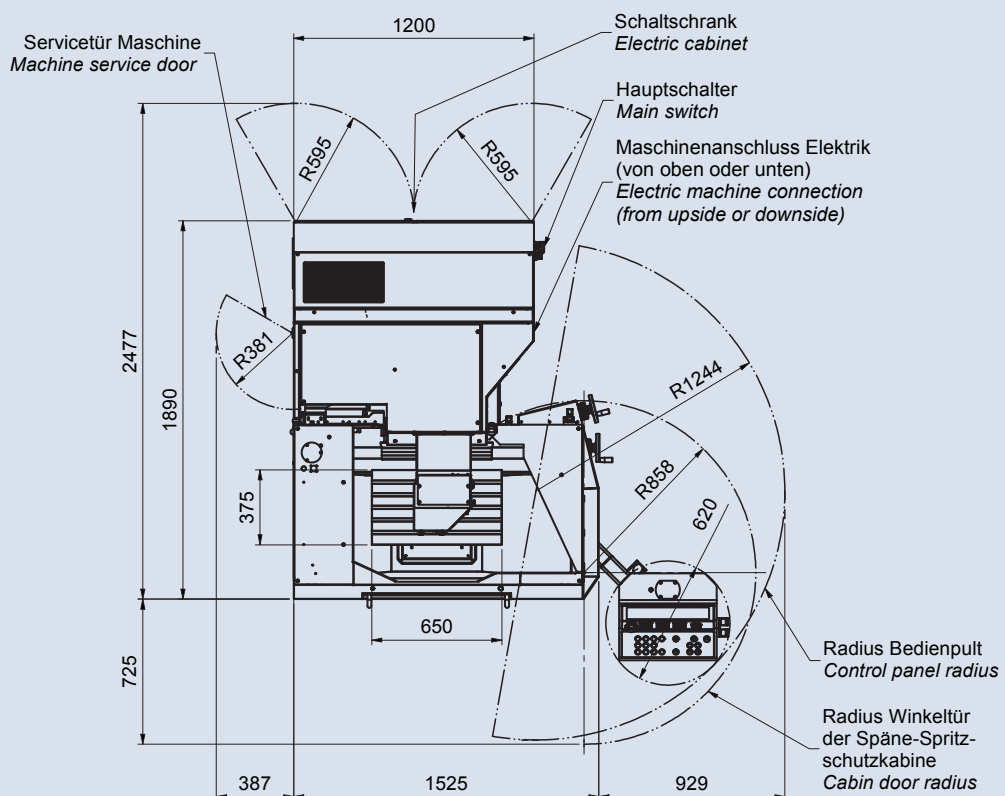



**WF 610 MC+**

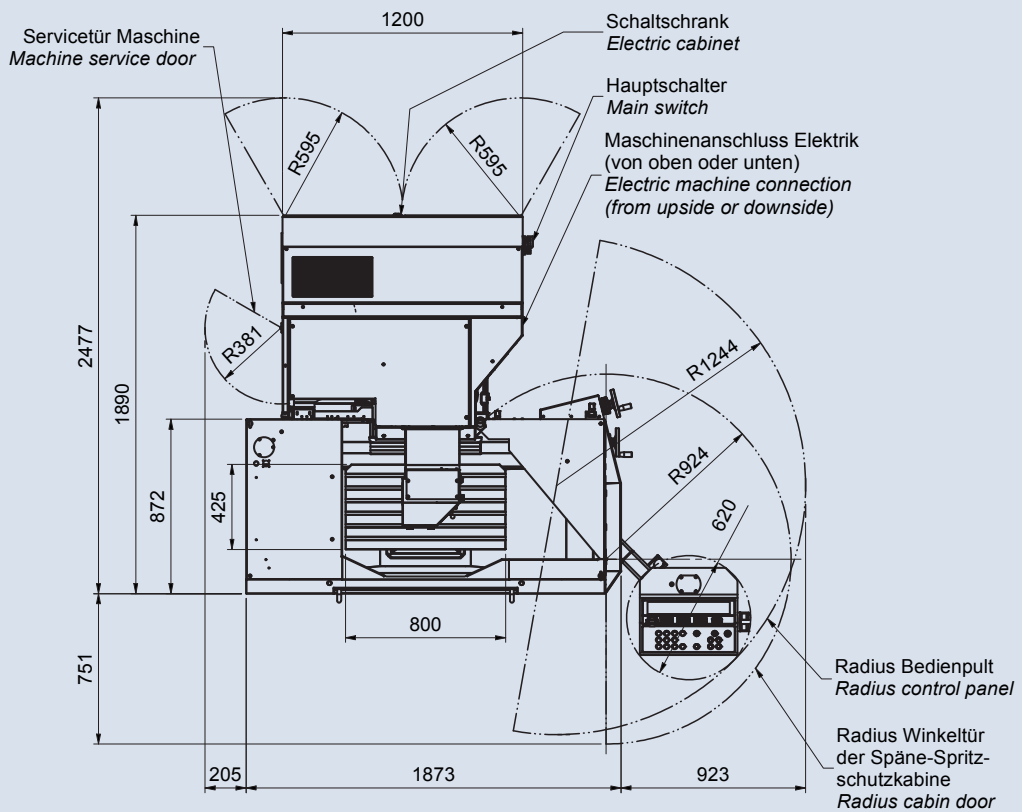

**STANDARDAUSRÜSTUNG**

- ▶ Vertical milling head with quill
- ▶ Linear guideways in all axes
- ▶ Ground ball screws
- ▶ Automatic central grease lubrication
- ▶ Manual handwheels
- ▶ Rigid angular table
- ▶ Oriented spindle stop
- ▶ Coolant tank, free-standing, 70 liters
- ▶ Maintenance time monitoring
- ▶ LED machine light
- ▶ Leveling elements

**OPTIONS**

- ▶ Motor spindle
- ▶ Universal tilting-swiveling table
- ▶ Linear encoders
- ▶ Electronic handwheel
- ▶ Chip rinsing unit with gun
- ▶ Collision protection couplings
- ▶ Touch probe systems
- ▶ CNC dividing heads
- ▶ Camera for working area
- ▶ KUNZMANN StateViewer PREMIUM
- ▶ Left maintenance door

<b>Working range</b> <b>410 MC+ / 610 MC+</b>	longitudinal, X axis cross, Y axis vertical, Z axis	410 / 610 mm 350 / 400 mm 450 mm
<b>Main drive</b> *at 1,500 rpm **at 2,000 rpm	<b>Milling head</b> perf. at 100% of duty cycle* perf. at 25% of duty cycle*	5.5 10.5
	<b>Motor spindle</b> perf. at 100% of duty cycle** perf. at 25% of duty cycle**	9 kW 14 kW
<b>Spindle speed</b>	Milling head Motor spindle	5,000 rpm 12,000 rpm
<b>Swiveling range</b>	Milling head	-5°/+90°
<b>Quill</b>	Milling head	70 mm-stroke
<b>Feed</b>	X ,Y, and Z axis	10 m/min
<b>Tool taper</b>	Milling head / motor spindle	SK 40 DIN 69871 HSK 63-A DIN 69893-1
<b>Angular table</b>	<b>WF 410 MC+</b> <b>WF 610 MC+</b>	650 x 375 mm 800 x 425 mm
<b>Universal tilting-swiveling table</b>	rotational angle digitally indicated	650 x 395 mm
<b>Control</b>	SIEMENS	SINUMERIK ONE
<b>Operating voltage</b>		400 V / 50 Hz
<b>Power consumption</b>		17 kVA
<b>Installation weight</b>	<b>WF 410 MC+</b> <b>WF 610 MC+</b>	approx. 2,100 kg approx. 2,200 kg



Visit our Website

**KUNZMANN®**  
FRÄSMASCHINEN

KUNZMANN Maschinenbau GmbH  
Tullastraße 29-31, 75196 Remchingen  
Phone: +49 (0) 7232 / 36 74-0  
Fax: +49 (0) 7232 / 36 74-74  
E-mail: info@kunzmann-fraemaschinen.de  
www.kunzmann-fraemaschinen.de

- ▶ Manufacturer of universal milling machines and vertical machining centers
- ▶ Expert technology consulting
- ▶ Customized application technology
- ▶ Individual programming trainings
- ▶ Fast and convenient after-sales support

Our strong partner

